

# INSTRUCTION MANUAL

## Water Rocket Explorer Little Bear

Scholz & Gallus GmbH  
Bessemerstraße 24/26 · 12103 Berlin · GERMANY  
Phone +49 30 98 38 80 17 · info@schoga.com

Thank you for purchasing the Little Bear water rocket base! With Little Bear, you have purchased a sustainable product that you will enjoy for many years to come. You can find lots of great ideas for building and operating water rockets under the search term »Water Rocket«, e.g. on YouTube.

Your Scholz & Gallus team



### Table of Contents

- Safety Instructions
- Operating Principle
- How do I recognize the bottle standards?
- Operation
- Maintenance
- Scope of Delivery / Technical Data
- What Else Is Possible
- Accessories
- Disposal

### Safety Instructions



Attention!

1. The water rocket launcher is not a toy. Children under the age of 14 should only use the water rocket launcher under adult supervision.

2. Any irregularities in the operation of the water rocket launcher may only be rectified by Scholz & Gallus itself. Otherwise any warranty will be void.
3. Any unauthorized modification, repair or manipulation – deviating from the instructions for use – leads to the exclusion of any liability.
4. The relief valve must not be adjusted. Operating the water rocket base without the relief valve is not permitted. The mechanical function of the relief valve must be checked before each operation by briefly pulling on the key ring.
5. Protective measures: A safety distance of 3 meters must be maintained when firing the rocket. The trigger string is exactly this length. **When the system and the rocket are under pressure – indicated by the manometer – never hold your head, torso, hands, arms or other parts of your body over the rocket. The rocket can reach its full terminal velocity at a height of 1 meter.** If the rocket gets stuck after release, wait until the pressure has been released by the internal safety valve. You will recognize this by a jet of water shooting out of the side of the launcher, which slowly dries up.
6. As soon as the rocket is pressurized, it must be launched quickly and must not be moved – e.g. carried around – under any circumstances. **Never underestimate the energy of a launching rocket!**
7. Make sure that falling rockets do not hit people or sensitive objects. Falling rockets must not pose any danger whatsoever.
8. Throw away any rockets or PET bottles that show visible signs of wear, such as creases, white spots, abrasion or similar.
9. Rockets with a defective impact absorber or defective tail unit may no longer be used.
10. When pressurizing the system, a pressure of 4.0 bar (58 psi) must not be exceeded. Inflation may only be carried out using a manual air pump.
11. The water rocket launcher should only be operated by one person. Avoid, for example, one person inflating while another is already holding the release cord.
12. These operating instructions must be kept in a safe place.

### Operating Principle

1. With the water rocket launcher, PET bottles converted into rockets can be shot into the air. Pressurized air and water serve as fuel.
2. The water rocket launcher should preferably be operated outdoors. Rockets can also be launched without water – i.e. with air only. In this way, the water rocket launcher can also be used indoors.
3. The two rockets supplied can be launched directly with the starter. To do this, the rockets are placed on the starter, where they snap into place and are held securely by the retaining claws until launch. The holding mechanism consists of the retaining claws and the PET thread on the rocket. The rocket is only held securely if both fit together. We use rockets with a long thread of the PCO-1810 standard, which fits the mounted retaining claws.
4. You can build your own rockets from commercially available disposable PET bottles. Please note that there are different thread standards and the retaining claws on the rocket must comply with the standard used. You can easily replace the retaining claws yourself.
5. EU: Shorter threads of the GME30.40 standard are widely used. Retaining claws are supplied for this standard if the country of delivery is an EU country.
6. Worldwide: There is also a standard with a shorter thread (PCO-1881). Retaining claws are supplied for this standard if the delivery address is outside the EU.

- Before using a disposable bottle as a rocket, the cap ring must be removed, as the retaining claws snap into place here.



Cap ring present



Cap ring removed

How do I recognize the bottle standards?

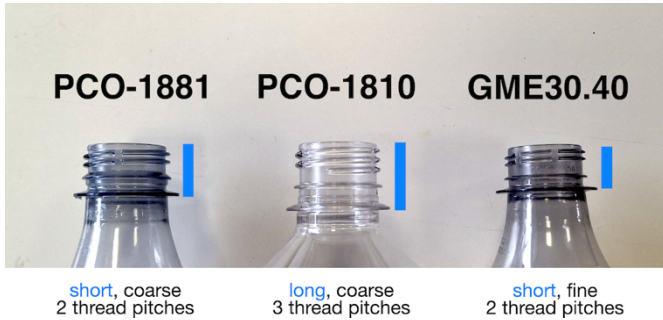

### Operation



Attention!

- When choosing the launch site, make sure that there are no bystanders, cars, etc. in the vicinity that could be injured or damaged when the rocket lands.
- Place the water rocket launcher on the ground and make sure that the base plate is well aligned horizontally. If necessary, the water rocket launcher can be secured with a peg to prevent it from slipping. To do this, use the fold-out anchor eye on the back of the water rocket launcher.
- Remove the valve cap and connect the air pump to the inlet valve. We strongly recommend using a bicycle air pump. An air pump is not included in the scope of delivery.
- Fill the rocket with approx. 500 ml of water. The two triangular markings show these points on the supplied rockets.
- Turn the rocket over and place the bottle opening over the coupling plug in one quick movement. Press the rocket down vertically with light pressure until the three retaining claws audibly click into place. With a little practice, only a very small amount of water will be lost during this process.
- Pump air into the water rocket launcher until the desired pressure is reached. Start with a low pressure for the first rocket launches.
- Take the wooden ball of the trigger string in your hand and move away from the water rocket launcher until the safe distance of 3 meters is reached, i.e. the release cord is slightly taut.
- Give the trigger string a gentle tug. Always pull the string lengthwise. Otherwise it will be more difficult and the string will suffer in the long run.
- If you are launching a rocket with air only, i.e. without water, it makes sense to moisten the bottle opening slightly beforehand. Tip: Glycerine is very suitable!

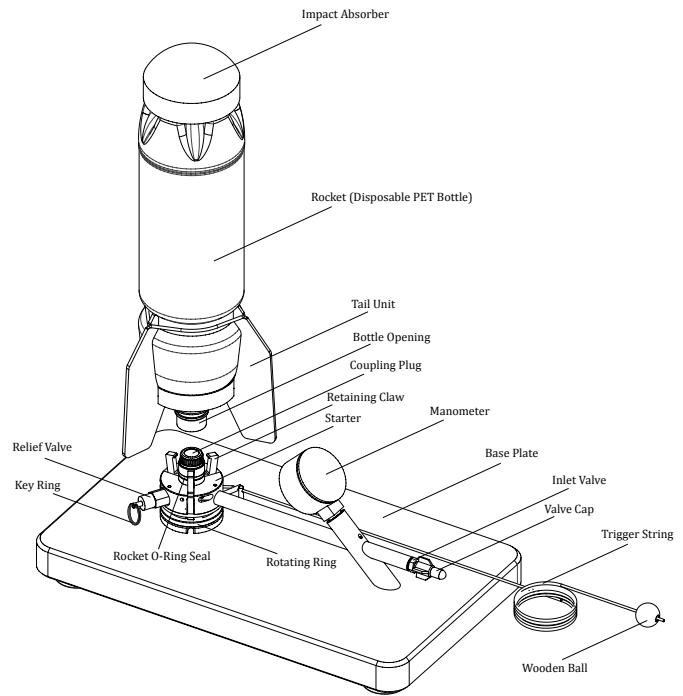

### Maintenance

- Make sure that there is no sand or similar on the starter spigot, on the edges of the bottle opening or in the rocket itself. Only ever operate the starter with the black screw plug – exception: The starter tube is screwed in. Otherwise dirt particles could get inside and cause the safety valve to leak.
- Blow out the pump: After experimenting, remove the pump from the water rocket launcher and operate it a few times to remove any water that may have entered.
- If you do not want to use the starter for a longer period of time, blow it out as well.
- If the starter becomes sluggish over time, you can lubricate it with a few drops of silicone oil. WD40 or similar products are not suitable as the seals could swell. Lubrication should always be carried out with the same lubricant.
- Proper functioning of the water rocket launcher is only guaranteed if the rocket O-ring seal is undamaged and the surrounding sealing surfaces are undamaged. Even minor scratches can lead to leaks. For this reason, the rocket O-ring seal and the adjacent surfaces should be checked regularly.
- The water rocket base is cleaned with clean drinking water. Always clean the water rocket launcher after contact with salt water. The launch base must never be operated with salt water.
- This model is intended exclusively for the function described above. We reserve the right to make technical changes.

## Scope of Delivery / Technical Data

1. Scope of Delivery (EU): Water rocket launcher Little Bear, two rockets and a set of retaining claws GME30.40  
Scope of Delivery (worldwide): Water rocket launcher Little Bear, two rockets and a set of retaining claws PCO-1881
2. Technical Data

Rocket length	380 mm
Rocket weight	110 g
Pressure	up to 4 bar (58 psi)
Altitude	up to 70 m (water) up to 25 m (air) up to 45 m (air + launch pipe)
Measurements	
Without rocket (H x W x L)	155 x 210 x 360 mm <sup>3</sup>
Weight without rocket	2.0 kg
Patent-No.	DE 10 2018 116 571 US 11,484,809

## What Else Is Possible

1. In order to reach even greater heights with the rockets, especially when launching with air only, a 25 cm long launch tube can be screwed into the launcher. The launch tube has exactly the same diameter as the bottle opening. In this way, the rocket can accelerate the first 25 cm without major pressure loss and thus make better use of the fuel.
2. Build a rocket with a parachute!
3. Measure the height reached by the rockets using angle bearings and triangulation. Or let an electronic sensor fly along!
4. Vary the physical parameters such as pressure, water volume, aerodynamic design and weight and observe what happens.
5. Build multi-stage rockets! And so on ...

## Accessories

1. Retaining claws for different bottle standards
2. Replacement Rocket
3. Launch Tube
4. Sensor Rocket
5. Parachutes
6. All parts of the water rocket launcher are also available as spare parts.

## Disposal

The product and packaging can be disposed of with normal household waste, but preferably via the appropriate recycling facilities.